

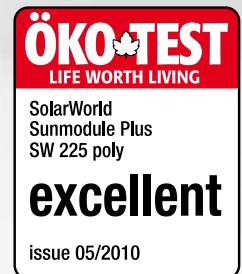

Length	680 mm
Width	680 mm
Height	34 mm
Frame	Aluminum
Weight	5,6 kg



Sunmodule®

SW 50 poly RMA

World class quality

SolarWorld produces the best products with the highest quality, manufactured according to German and US quality standards in fully-automated ISO 9001 and 14001 certified factories.

Outstanding products

SolarWorld's modules were assessed by the ÖKO-TEST consumer magazine as "excellent".

An experienced industry leader

With over 30 years of experience in off-grid solar applications – SolarWorld delivers top products and technical experience at the highest levels. Our modules are installed in over 100,000 Telecom/Industrial systems worldwide. Nobody else comes close.



Sunmodule®

SW 50 poly RMA

PERFORMANCE UNDER STANDARD TEST CONDITIONS (STC)*

		SW 50
Maximum power	P_{max}	50 Wp
Open circuit voltage	U_{oc}	22,1 V
Maximum power point voltage	U_{mpp}	18,2 V
Short circuit current	I_{sc}	2,95 A
Maximum power point current	I_{mpp}	2,75 A

*STC: 1000W/m², 25°C, AM 1.5

PERFORMANCE AT 800 W/m², NOCT, AM 1.5

		SW 50
Maximum power	P_{max}	35,9 Wp
Open circuit voltage	U_{oc}	19,8 V
Maximum power point voltage	U_{mpp}	16,3 V
Short circuit current	I_{sc}	2,38 A
Maximum power point current	I_{mpp}	2,2 A

Minor reduction in efficiency under partial load conditions at 25°C: at 200W/m², 95% (+/-3%) of the STC efficiency (1000 W/m²) is achieved.

COMPONENT MATERIALS

Cells per module	36
Cell type	Poly crystalline
Cell dimensions	62 mm x 156 mm
Front	tempered glass (EN 12150)

SYSTEM INTEGRATION PARAMETERS

Maximum system voltage SC II	1000 V
Maximum reverse current	12 A
Number of bypass diodes	2

THERMAL CHARACTERISTICS

NOCT	46 °C
TC I_{sc}	0,034 %/K
TC U_{oc}	-0,34 %/K
TC P_{mpp}	-0,48 %/K

ADDITIONAL DATA

Power tolerance	+/- 10 %
Junction box	IP65
Maximum outer cable diameter	6,9 mm
Maximum wire cross section	4 mm ²

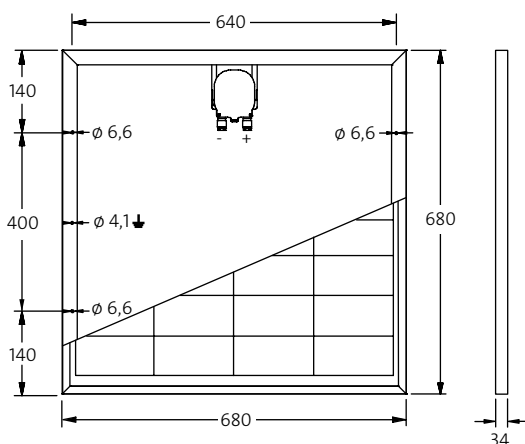

- Qualified, IEC 61215
- Safety tested, IEC 61730
- Periodic Inspection

